

Type No:MC420-381  
Order No:MC420-3810698Z

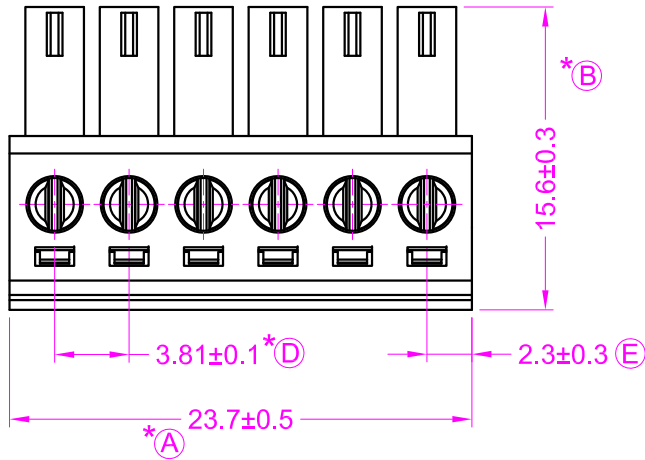

參考文件  
2023.12.14  
研發部



字型:ARAIL  
字高:1.75mm  
顏色:黑色

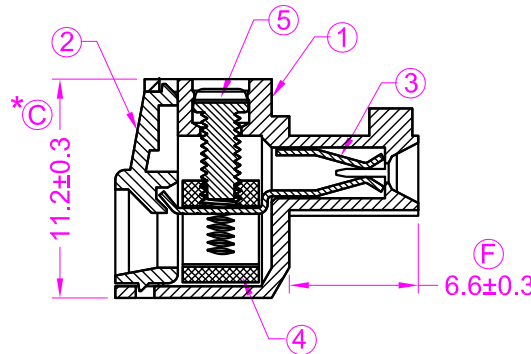
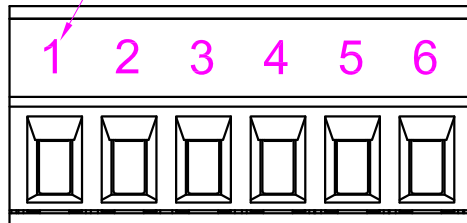

Technical data in accordance to UL/CUL :  
Current rating : 10Amp 300V (UG B/D)  
Insulation withstands volt : AC1600V min  
Insulation resistance : >2000MΩ DC500V  
Operation temperature : -40°C to +105°C  
Wire range : 16~26 AWG  
Wire strip length : 5.5~6.5mm  
Screw torque : 3 lb-inch  
Approval data in accordance to IEC EN61984 :  
Rated Insulation voltage : 300V  
Rated current : 8A  
Wire range : 0.2mm<sup>2</sup>~ 1.5mm<sup>2</sup> (rigid solid, flexible)

CONFIRMED & ACCEPTED BY:

	Material	Plating/Finish	Remark
1	Insulating body Polyamide 66(UL94V-0)		Green
2	Cover Polyamide 66(UL94V-0)		Green
3	Contact Phosphor bronze	Tin plated	
4	Cage clamp Brass	Ni plated	
5	Screw Steel	Zinc plated	
6			

**DECA<sup>®</sup>SwitchLab Inc.**

DESIGN	CHECK	APPROVE
DATE	DATE	DATE
2023/12/14	2023/12/14	2023/12/14

PART NAME	UNIT	SCALE
Terminal Blocks	MM	
DRAWING NO.		SHEET
MC420-3810698Z		1 / 1

A
REV.