

六角螺絲 H4.7 x 11.8 x #4-40UNC

SPECIFICATIONS

Material: Brass
 Plating: Nickel Plated

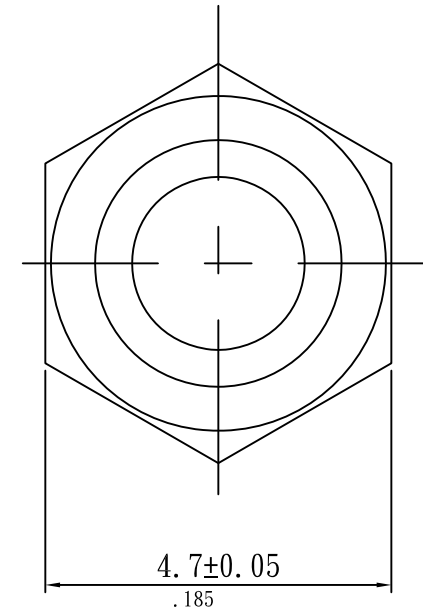
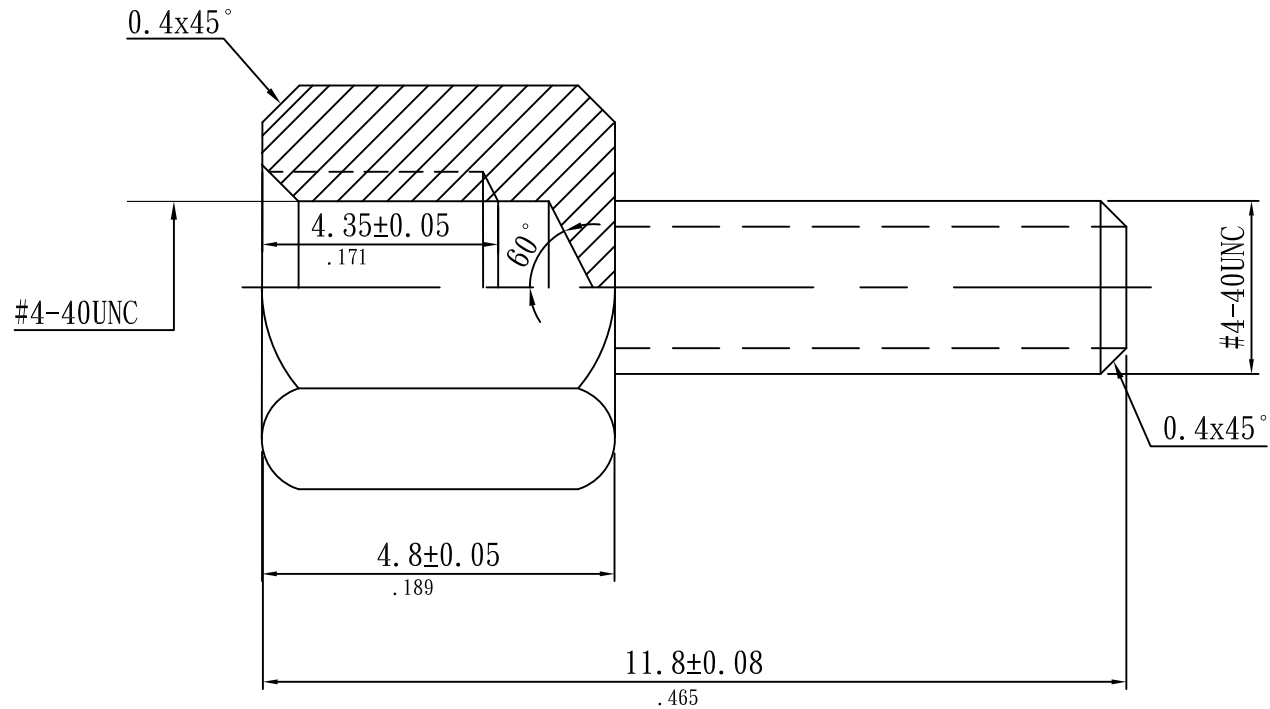

S.Y.E. Sunny Young Enterprise Co., Ltd.
 S. Y. E. <http://www.sunnyyoung.com.tw>
 13F., No. 116, Sec. 1, Xintai 5th Rd., Xizhi Dist., New Taipei City 221, Taiwan
 Tel: +886 2 2696 1668(REP) Fax: +886 2 2696 2668

L168	NAME	DATE	SCALE: NTS	REV NO	DATE	DESCRIPTION	BY	CHECKED	TOLERANCE UNLESS NOTED		
DRAWN	RALF	2019.04.19	UNIT: mm(in.)	A					LINEAR±	.0 ±0.30(.012)	
CHECKED	EASON	2019.04.19	CAD NO	B				.00 ±0.20(.008)			
APPROVED	APPLE	2019.04.19	R7300-HS-48-118	C				.000±0.10(.004)			
PART NO	R7300-HS-48-118		APPROVED		APPLE	2019.04.19	R7300-HS-48-118	C	PROJECTION:		

HEX NUT #4-40x4.95x1.90

MATERIAL

Nut: Steel
 Plating: Nickel plated

Order information

R 7300-HC-50
 1 2 3 4

1. RoHS
2. Series No.
3. Hex cold
4. H:4.95

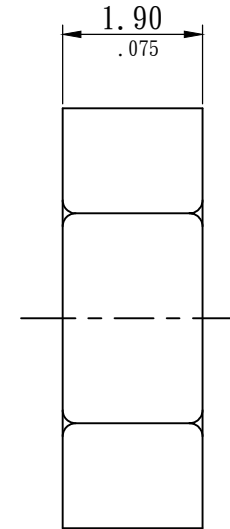
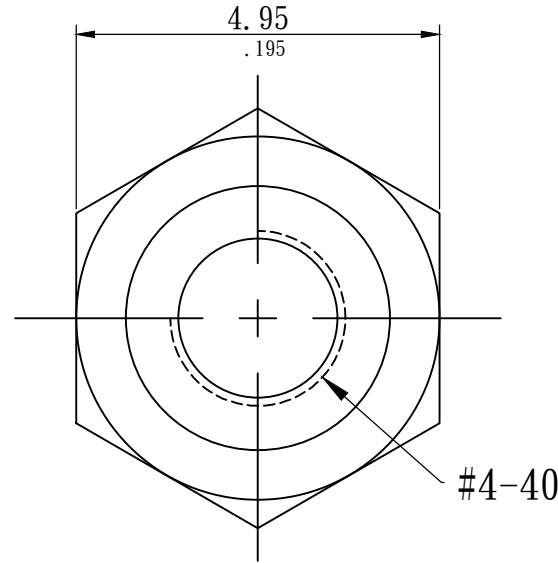

 Sunny Young Enterprise Co., Ltd.
 S. Y. E. <http://www.sunnyyoung.com.tw>
 13F., No. 116, Sec. 1, Xintai 5th Rd., Xizhi Dist., New Taipei City 221, Taiwan
 Tel: +886 2 2696 1668(REP) Fax: +886 2 2696 2668

S001	NAME	DATE	SCALE: 10:1	REV NO	DATE	DESCRIPTION	BY	CHECKED	TOLERANCE UNLESS NOTED	
DRAWN	RALF	2023. 11. 28	UNIT: mm(in.)	A					LINEAR±	.0 ±0.38(.015)
CHECKED			CAD NO	B						.00 ±0.25(.010)
APPROVED			R7300-HC-50	C					PROJECTION: 	

PART NO R7300-HC-50

SPRING WASHER

MATERIAL

Nut: Steel
Plating: Nickel plated

Order information

R SW-SW-032-053-007
1 2 3 4 5 6

1. RoHS
2. Screw Series No.
3. Spring washer
4. Inner diameter
5. Outer diameter
6. Thickness

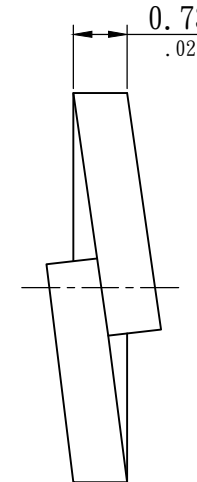
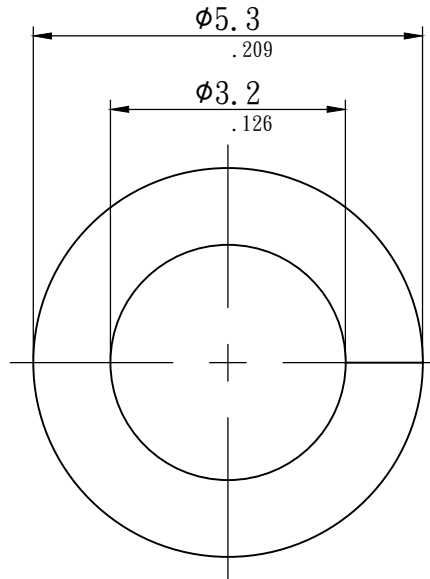

 Sunny Young Enterprise Co., Ltd.
S. Y. E. <http://www.sunnyyoung.com.tw>
13F., No. 116, Sec. 1, Xintai 5th Rd., Xizhi Dist., New Taipei City 221, Taiwan
Tel: +886 2 2696 1668(REP) Fax: +886 2 2696 2668

PART NO RSW-SW-032-053-007

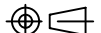
S001	NAME	DATE	SCALE: 10:1	REV NO	DATE	DESCRIPTION	BY	CHECKED	TOLERANCE UNLESS NOTED	
DRAWN	RALF	2023. 11. 28	UNIT: mm(in.)	A					LINEAR±	.0 ±0.50(.020)
CHECKED			CAD NO	B						.00 ±0.25(.010)
APPROVED			RSW-SW-032-053-007	C					PROJECTION: 	

FLAT WASHER

MATERIAL

Nut: Steel
 Plating: Nickel plated

Order information

R SW-FW-030-050-005
 1 2 3 4 5 6

1. RoHS
2. Screw Series No.
3. Flat washer
4. Inner diameter
5. Outer diameter
6. Thickness

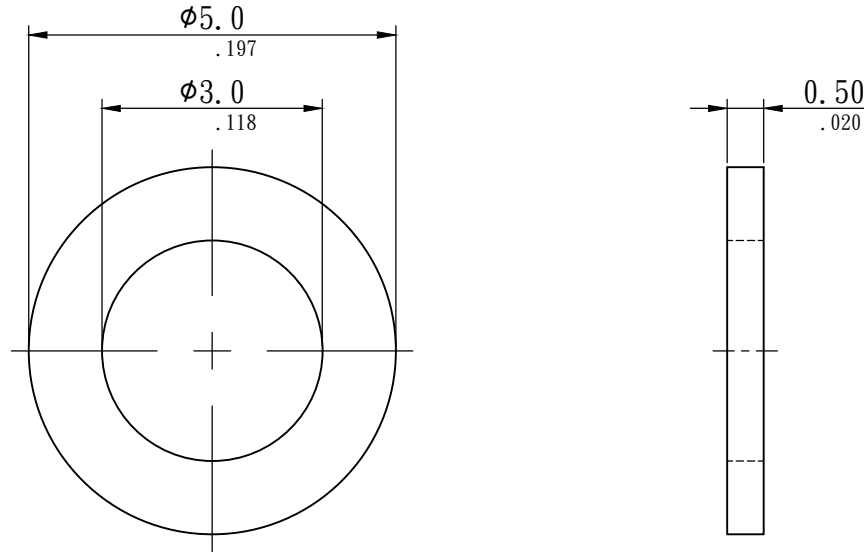

 Sunny Young Enterprise Co., Ltd.
 S. Y. E. <http://www.sunnyyoung.com.tw>
 13F., No. 116, Sec. 1, Xintai 5th Rd., Xizhi Dist., New Taipei City 221, Taiwan
 Tel: +886 2 2696 1668(REP) Fax: +886 2 2696 2668

S001	NAME	DATE	SCALE: 10:1	REV NO	DATE	DESCRIPTION	BY	CHECKED	TOLERANCE UNLESS NOTED	
DRAWN	RALF	2023. 11. 29	UNIT: mm(in.)	A					LINEAR±	.0 ±0.38(.015)
CHECKED			CAD NO	B						.00 ±0.25(.010)
PART NO	RSW-FW-030-050-005		APPROVED			RSW-FW-030-050-005	C			PROJECTION: 